

Thank you for purchasing this Autel calibration tool. This tool, manufactured to a high standard will, if used according to the instructions and properly maintained, ensure you years of trouble-free performance.



WARNING:

- Serious or fatal injuries can occur from frame tip-over so it must be secured to the ground during the assembly.
- Improper assembly of the equipment may cause permanent damage and may render it inoperable and/or unsafe.

Table of Contents

1. Check Packs and Part Lists	1
1.1 List of Packs	1
1.2 Part Lists	1
2. Assembly Procedures	3
2.1 Assemble Calibration Frame	3
2.2 Assemble Crossbar	4
2.3 Assemble Calibration with Crossbar	8
2.4 Attach the Pattern Board	8

1. Check Packs and Part Lists



1.1 List of Packs

Before opening packages, ensure the following items are all received.

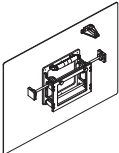

Radar Calibration Plate AUTEL-CSC0G02/01	MaxiSys ADAS (Calibration Frame)	MaxiSys ADAS (Crossbar)
MaxiSys ADAS (Wheel Clamp)	Storage Bag for Night Vision Calibration	Pattern Board 0G0006
Point Laser Auxiliary Dial AUTEL-CSC0500/05	Pattern Autel CSC0601/07	NV Calibrator 100000936 AUTEL-CSC0603/01

1.2 Part Lists





Part List of Radar Calibration Plate AUTEL-CSC0G02/01

Radar Calibration Plate AUTEL-CSC0G02/01 	1pc
Extension Holder 	1pc



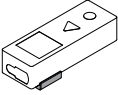
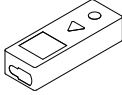

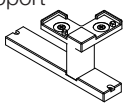

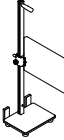
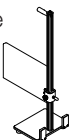
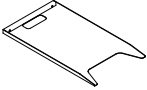



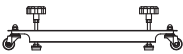
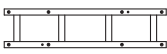
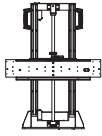

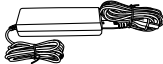

Part List of MaxiSys ADAS (Wheel Clamp)

Wheel Clamp CSC0500/01 	2pcs	Laser CSC0500/02 	2pcs
Wheel Clamp Extender 0G0017 	8pcs		

Part List of Point Laser Auxiliary Dial AUTEL-CSC0500/05

Center Laser Unit 0G0010 	1pc	Side Laser Unit 0G0012 	2pcs	Side Laser Unit Support 0G0013 	2pcs	Center Laser Unit Support 0G0011 	1pc
Bolt (M3x16) 	2pcs	Hex L-wrench (2mm) 	1pc	Left Reference Board 0G0014 	1pc	Right Reference Board 0G0015 	1pc
Extension Board 0G0016 	2pcs						

Part List of MaxiSys ADAS (Calibration Frame)

Base Holder 060001 	2pcs	Base Crossbar 060002 	1pc	Lifter 060003 	1pc	Round Handle 060007 	1pc
24V Power Adapter 060009 	1pc	Bolt (M8x20) 060015 	8pcs	Bolt (M5x30) 060016 	12pcs	Bolt (M4x10) 	12pcs
Flat Washer (M8) 060017 	8pcs	Hex L-wrench (6mm) 060011 	1pc	Hex L-wrench (4mm) 060032 	1pc	Hex L-wrench (3mm) 	1pc
Lock Washer 060018 	8pcs	Left Hanger 0G0018 	1pc	Right Hanger 0G0019 	1pc	Sliding Laser Plate 060031 	1pc

Part List of Storage Bag for Night Vision Calibration

Storage Bag for Night Vision Calibration CSC0500/15 	1pc
---	-----

Part List of Pattern Autel CSC0601/07

Pattern CSC0601/07 	1pc
--	-----







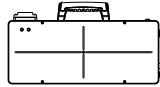



Part List of Pattern Board 0G0006

Pattern Board CSC0611/01 	1pc
--	-----

Part List of NV Calibrator 10000936 AUTEL-CSC0603/01

NV Calibrator CSC0603/01 	1pc
---	-----

Part List of MaxiSys ADAS (Crossbar)

Crossbar CSC0G00/05 	1pc	Left Extended Bar 0G0008 	1pc	Right Extended Bar 0G0009 	1pc	Left Mirror 0G0006 	1pc
Bolt (M6x10) 	4pcs	Bolt (M5x10) 	4pcs	Hex L-wrench (3mm) 	1pc	Right Mirror 0G0007 	1pc
Bolt (M4x10) 	8pcs	Locking Pillar 	4pcs	Hex L-wrench (2.5mm) 060032 	1pc		

Note:

1. To guarantee safe storage, please keep the "NV Calibrator (100000936 AUTEL-CSC0603/01)" in the Night vision calibrator storage bag.
2. Each carton box has a part list inside. Please check the accessories against the part list one by one to ensure a complete delivery.

2. Assembly Procedures

2.1 Assemble Calibration Frame

Take out parts from the (Calibration Frame) box and perform as below:

Assemble the Base

1

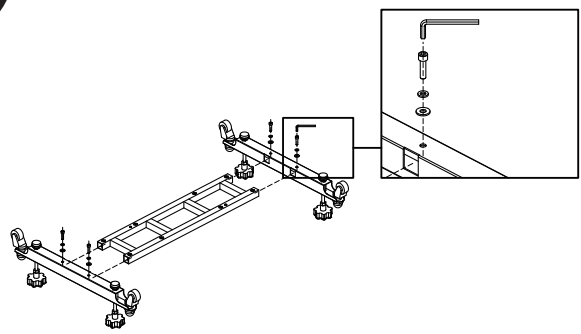

1. Place the two base holders on a flat with the knobs on the ground. Insert the base crossbar into the base holder slots.
2. Position the flat washer (M8) to secure the base crossbar to the base holders, lock washer over each of the four screw holes, insert the bolt (M8x20) and tighten with the hex L-wrench (6mm).

2

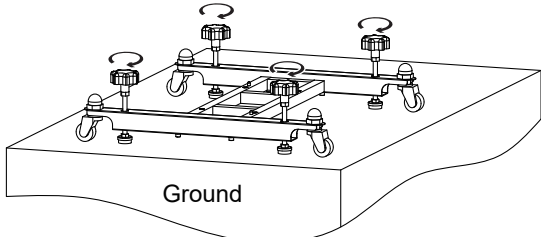

Turn over the base so it is now resting on its wheels. Rotate each of the four hand knobs clockwise to secure the base to the ground.

Attach lifter to base

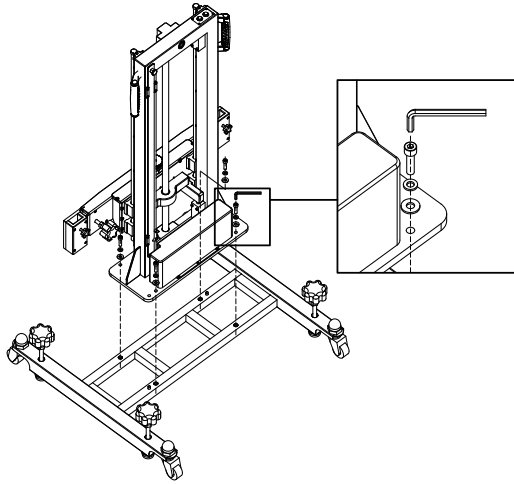

Step 1: Place the lifter on top of the base. Align each of the four screw holes on the lifter with those on the base.

Step 2: Position the flat washer (M8), lock washer over each of the screw holes, insert and tighten the bolt (M8x20) with the hex L-wrench (6mm). Ensure the base and the lifter are firmly attached.

Secure the hangers

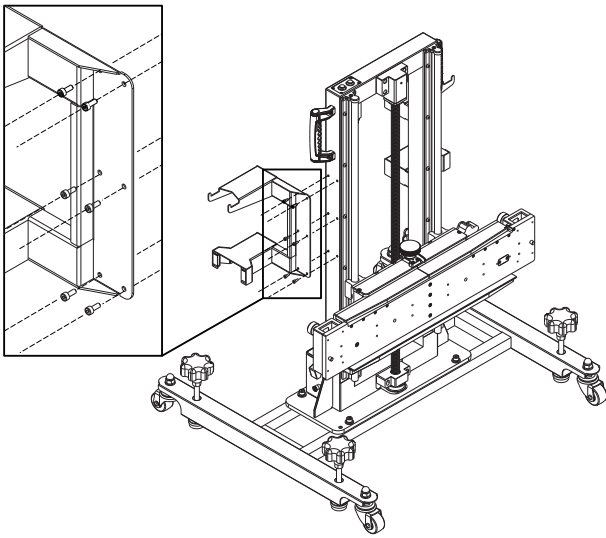

As is shown in the picture, fix the left hanger to the lifter with the bolt (M4x10) using a 3mm hex L-wrench. Then fix the right hanger with the bolt (M4x10) on the opposite side. Make sure the hooks on the hangers face upward on the round handle side.

2.2 Assemble Crossbar

Take out parts from the MaxiSys ADAS (Crossbar) box and Point Laser Auxiliary Dial AUTEL-CSC0500/05 box, perform as below:

Assemble laser and auxiliary dial on both ends of the crossbar

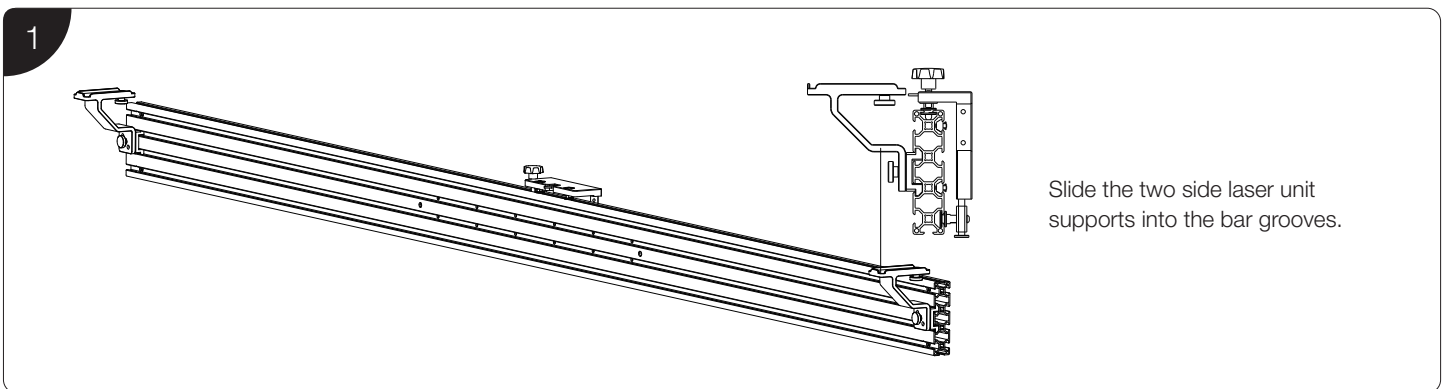

Slide the two side laser unit supports into the bar grooves.

2

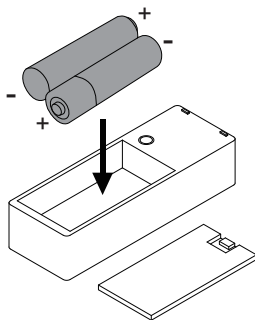

Remove the back cover of the side laser unit, insert 2 AAA batteries and put the cover back in place.

3

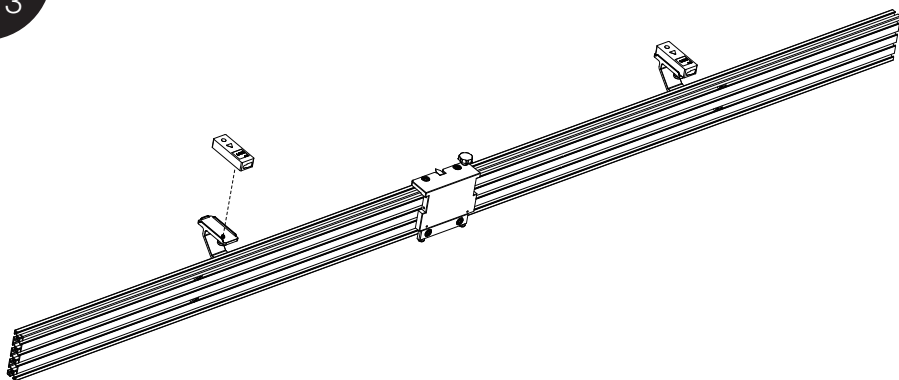

Align the screw hole on the back of the side laser unit with the hole on side laser unit support, and tighten with knob.

4

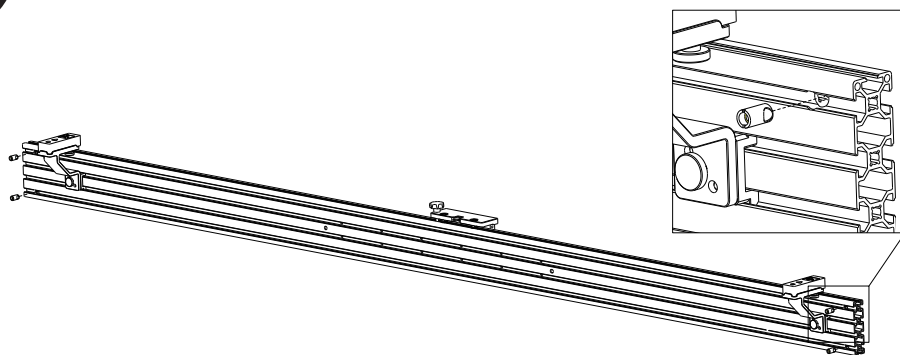

Put the four locking pillars into the step holes on the both ends of the crossbar with the notch perpendicular to the crossbar axis.

Install the two extended bars on both ends of the crossbar

1

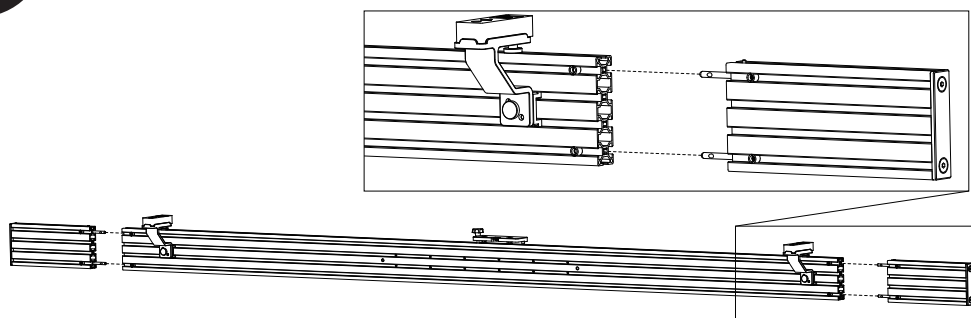

Insert the shafts of the two extended bars into the holes of the crossbar and locking pillars.

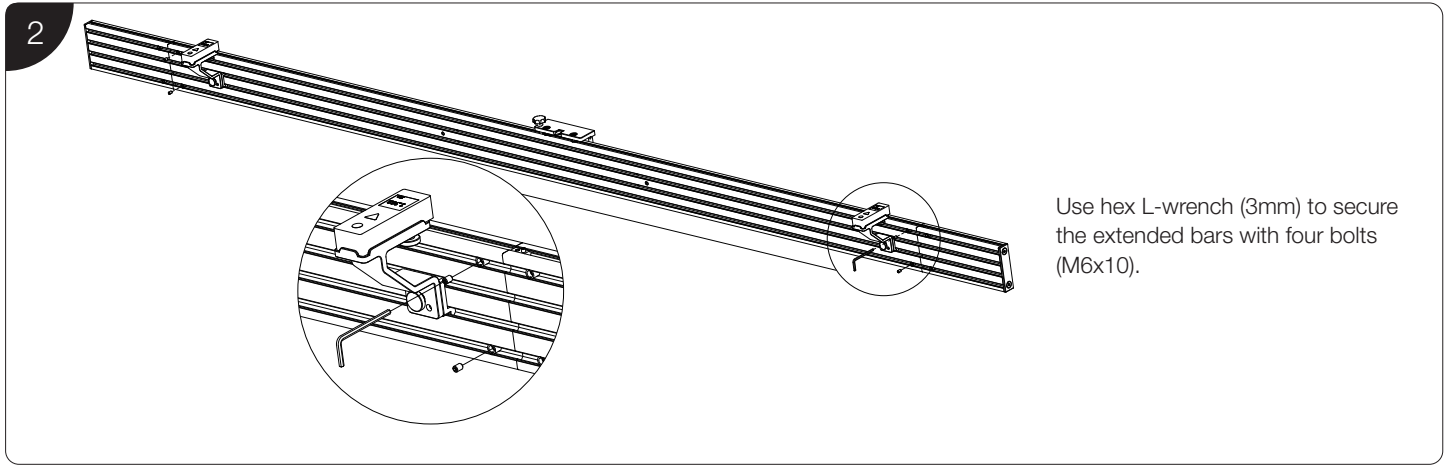

Install the mirror (2 pcs) on both ends of the crossbar

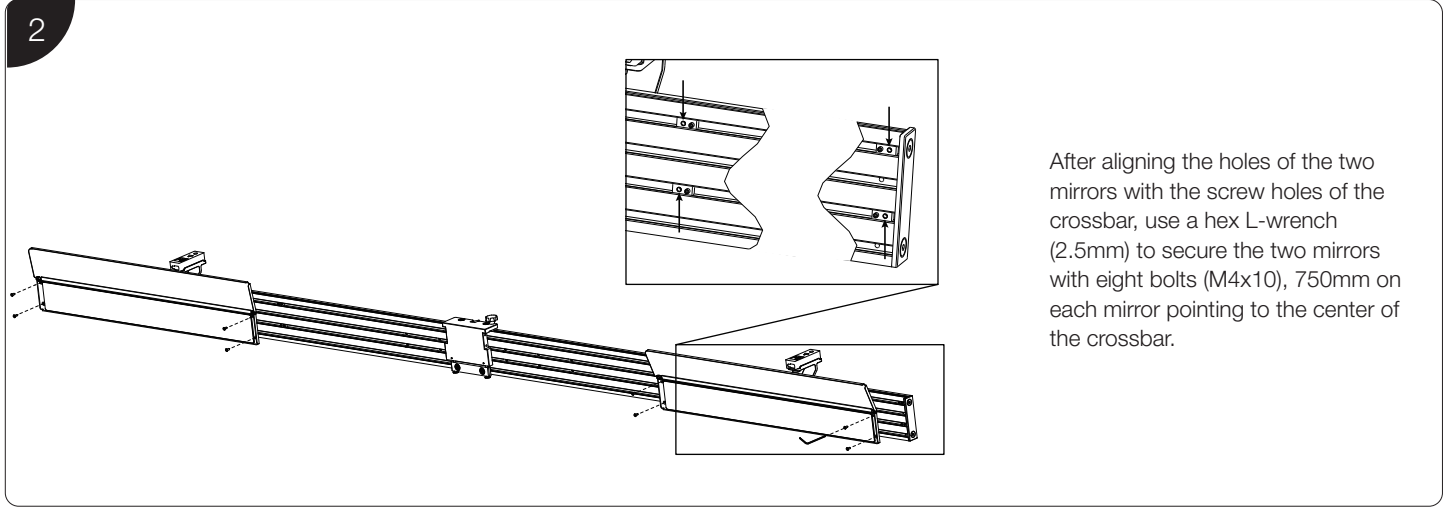
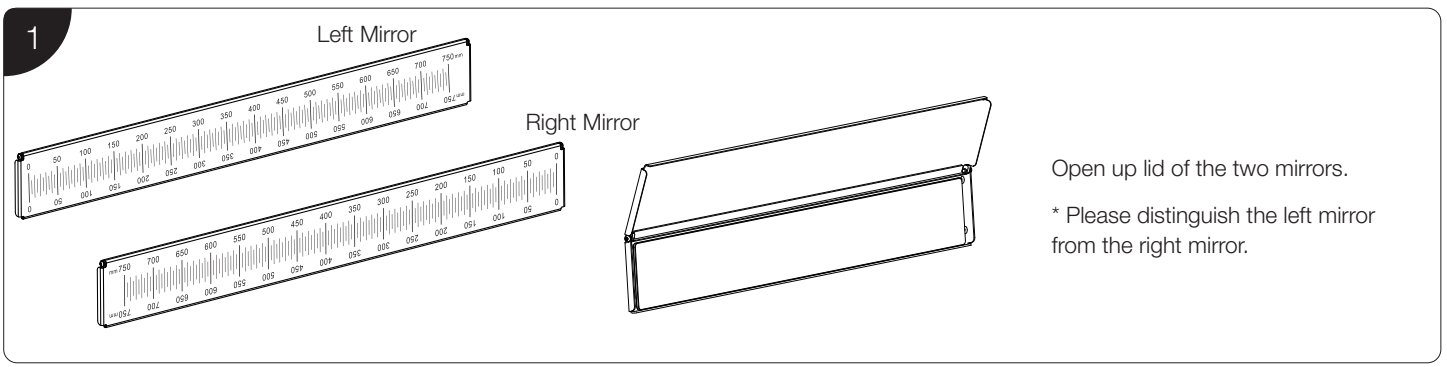

Assemble laser and auxiliary dial and secure to the center of crossbar

1

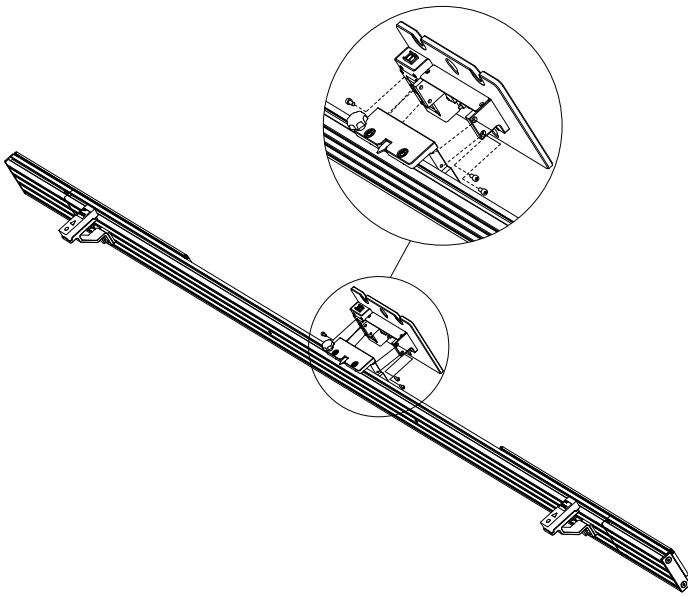

Take out the crossbar and the sliding laser plate from the package cartons respectively.

Attach the crossbar sliding plate to the center of the crossbar, insert four bolts (M5x10) on the side view and tighten them with the hex L-wrench (4mm). Ensure the crossbar sliding plate is securely attached to the crossbar.

2

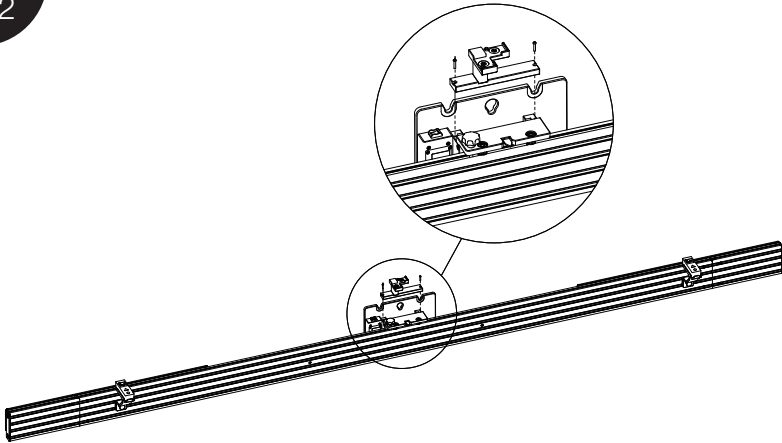

Align the screw holes on the center laser unit support with the screw holes on the sliding laser plate, insert two bolts (M3x16) and tighten with hex L-wrench (2mm).

3

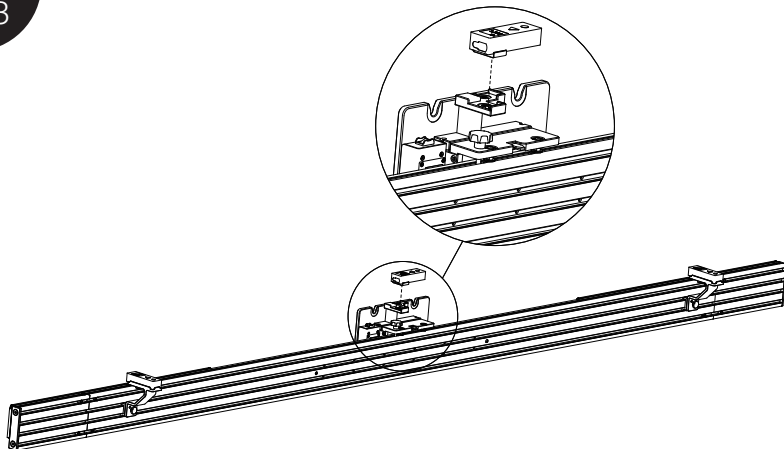

Insert 2 AAA batteries. Align the holder on the back of the center laser unit with the center laser unit support, place it on the center laser unit support and ensure the laser is parallel to the sliding laser plate. Move the sliding laser plate back to the center of the crossbar and tighten the knob.

2.3 Assemble Calibration with Crossbar

Secure lift to the base

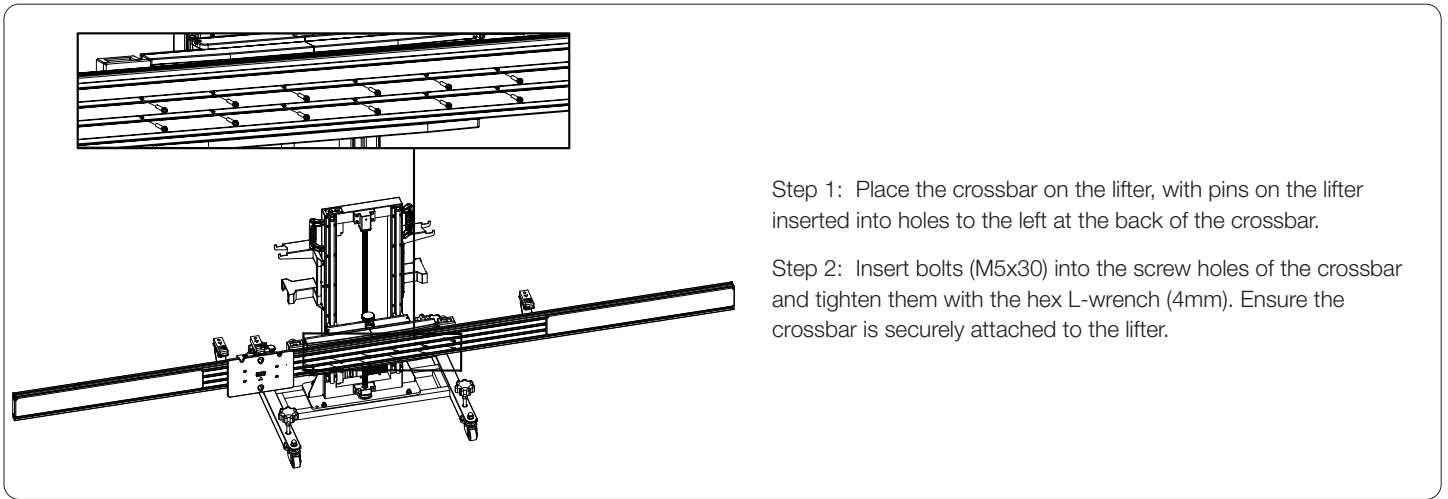

Install round handle/connect power adapter

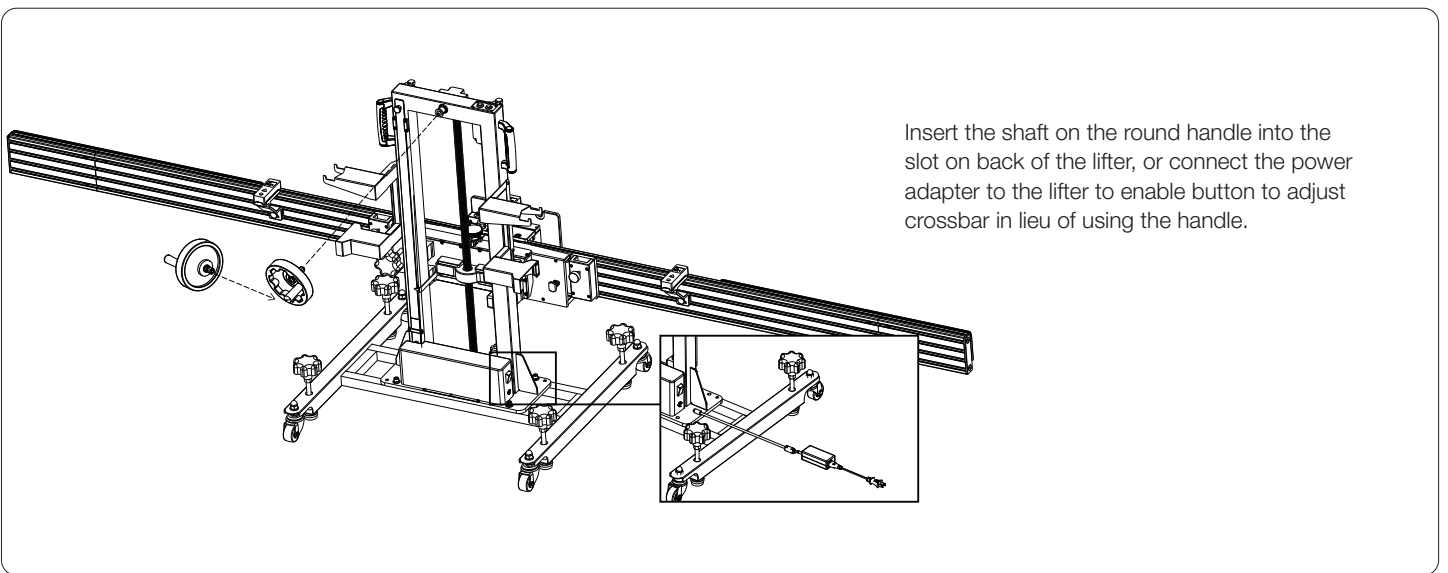

2.4 Attach the Pattern Board

Take out parts from the Pattern Board 0G0006 box and perform as below:

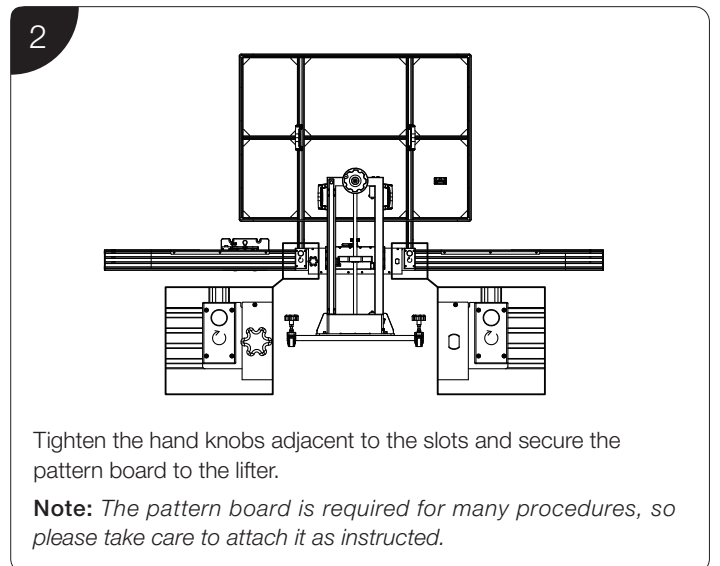
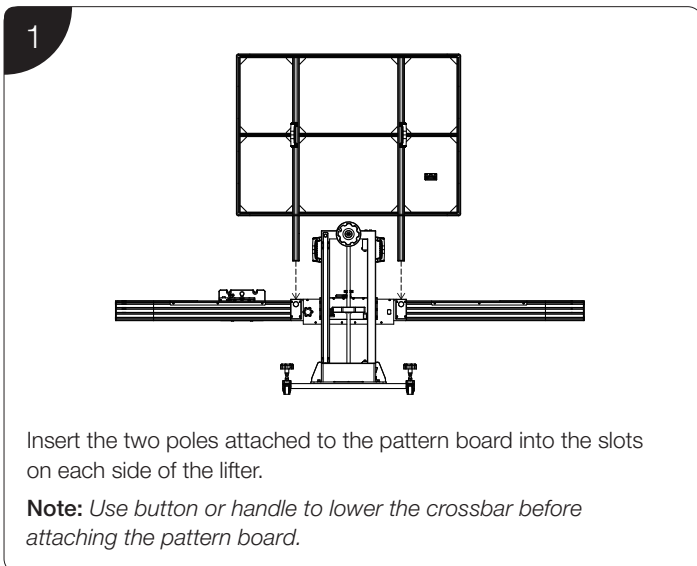

Note: After the above procedures, please store the equipment properly.